

---

# **6-inch IR Intelligent Speed Dome Installation Manual**

**Version 1.0.0**

---

# Table of Contents

<b>1</b>	<b>INSTALLATION PREPARATION</b> .....	<b>1</b>
1.1	Basic Requirements.....	1
1.2	Installation Check .....	1
1.3	Cable Preparation .....	1
1.3.1	Cable Lowest Specification Requirement.....	1
1.3.2	Select Needed Power Supply Cable According to Transmission Distance.....	2
<b>2</b>	<b>SPEED DOME INSTALLATION</b> .....	<b>3</b>
2.1	Check Accessories .....	3
2.2	Open the Device .....	3
2.3	DIP Switch Setup.....	3
2.3.1	DIP Switch Location and Function.....	3
2.3.2	DIP Switch Setup .....	5
2.3.3	Address Setup .....	5
2.3.4	Baud Rate and Parity Setup .....	5
2.4	Terminal Matched Resistance Setup .....	7
2.5	Reset Button Location and SD Card Installation .....	7
2.6	Speed Dome Installation .....	8
2.6.1	Install Quick Mounting Connector.....	8
2.7	Speed Dome Installation .....	9
2.7.1	Install Quick Mount Connector.....	9
2.7.2	Speed Dome Cable .....	10
2.7.3	Install the speed dome.....	12
<b>3</b>	<b>WALL-MOUNTED BRACKET INSTALLATION</b> .....	<b>14</b>
3.1	Mounting Component and Dimension .....	14
3.2	Wall-mounted Bracket Installation Steps .....	15
3.2.1	Installation Conditions.....	15
3.2.2	Installation Steps .....	15
<b>4</b>	<b>HANG-MOUNTED BRACKET INSTALLATION</b> .....	<b>17</b>

<b>4.1</b>	<b>Mounting Component and Dimension .....</b>	<b>17</b>
<b>4.2</b>	<b>Hang-mounted Bracket Installation Steps.....</b>	<b>18</b>
4.2.1	Installation Conditions.....	18
4.2.2	Installation Steps .....	18
<b>5</b>	<b>CORNER-MOUNTED BRACKET INSTALLATION.....</b>	<b>20</b>
<b>5.1</b>	<b>Mounting Component and Dimension .....</b>	<b>20</b>
<b>5.2</b>	<b>Corner-mounted Bracket Installation Steps.....</b>	<b>21</b>
5.2.1	Installation Conditions.....	21
5.2.2	Installation Steps .....	21
<b>6</b>	<b>POLE-MOUNTED BRACKET INSTALLATION .....</b>	<b>23</b>
<b>6.1</b>	<b>Mounting Component and Dimension .....</b>	<b>23</b>
<b>6.2</b>	<b>Pole-mounted Bracket Installation Steps .....</b>	<b>24</b>
6.2.1	Installation Conditions.....	24
6.2.2	Installation Steps .....	24
<b>7</b>	<b>APPENDIX I LIGHTNING PROOF AND SURGE PROTECTION.....</b>	<b>26</b>
<b>7.1</b>	<b>Outdoors .....</b>	<b>26</b>
<b>7.2</b>	<b>Indoors .....</b>	<b>27</b>
<b>8</b>	<b>APPENDIX II ABOUT RS485 BUS .....</b>	<b>28</b>
<b>8.1</b>	<b>RS485 Bus Main Feature .....</b>	<b>28</b>
<b>8.2</b>	<b>RS485 Bus Transmission Distance.....</b>	<b>28</b>
<b>8.3</b>	<b>The Problem in Practical Use .....</b>	<b>28</b>
<b>8.4</b>	<b>RS485 Bus FAQ.....</b>	<b>29</b>
<b>9</b>	<b>APPENDIX III THE RELATIONSHIP BETWEEN AC 24V CABLE DIAMETER AND TRANSMISSION DISTANCE.....</b>	<b>30</b>
<b>10</b>	<b>APPENDIX IV THE RELATIONSHIP BETWEEN DC 12V CABLE DIAMETER AND THE TRANSMISSION DISTANCE.....</b>	<b>31</b>
<b>11</b>	<b>APPENDIX V THE RELATIONSHIP BETWEEN DC 24V CABLE DIAMETER AND THE TRANSMISSION DISTANCE.....</b>	<b>32</b>
<b>12</b>	<b>APPENDIX IV THE RELATIONSHIP BETWEEN DC 36V CABLE DIAMETER AND THE TRANSMISSION DISTANCE.....</b>	<b>33</b>

---

<b>13 APPENDIX IV THE RELATIONSHIP BETWEEN DC 48V CABLE DIAMETER AND THE TRANSMISSION DISTANCE.....</b>	<b>34</b>
<b>14 APPENDIX IV WIRE GAUGE REFERENCE SHEET .....</b>	<b>35</b>

---

## **Welcome**

Thank you for purchasing our speed dome!

**Please read the following safeguards and warnings carefully before you install or use the product!**

---

# Important Safeguards and Warnings

## Safety Measures

### 1. Qualified Engineer Needed

- The installation engineer or maintenance engineer shall have corresponding CCTV system installation certificate or maintenance qualification certificate.
- The installation engineer or maintenance engineer shall have qualification certificate for work at height.
- The installation engineer or maintenance engineer shall have the basic knowledge and operation technique for low-voltage cable layout and low-voltage electronic cable connection.
- Please read the installation manual carefully and keep it well for future reference,
- We are not liable for any problems caused by unauthorized modifications or attempted repair.

### 2. Lifting Appliance Requirement

- Please select the proper speed dome installation mode and use the lifting appliances at the safety environment.
- The lifting appliances shall have the enough capacity to reach the installation height.
- The lifting appliances shall have safe performance.

**The precaution measures include two types: Warning and Note.**

- **Warning:** It is to alert you there is an optional risk of death or series injury!
- **Note:** It is to alert you there is an optional risk of damage or property loss!

## Warning

1. All installation and operation here should conform to your local electrical safety codes. We assume no liability or responsibility for all the fires or electrical shock caused by improper handling or installation.
2. Be sure to use all the accessories (such as power adapter) recommended by manufacturer.
3. Laser light is dangerous; please do not look at it straight.
4. Do not connect several speed domes to one power adapter. It may result in overheat or fire if it exceeds the rated load.
5. Before you connect the cable, install or uninstall, or begin the daily maintenance work, please turn off the power and unplug the power cable.
6. Please make sure the produce is secure firmly on the wall or the ceiling.

- 
7. Please turn off the power and unplug the power cable, If there is any smoke, disgusting smell, or noise. Please contact your local retailer or customer service centre for help.
  8. All the examination and repair work should be done by the qualified service engineers. We are not liable for any problems caused by unauthorized modifications or attempted repair.

## Note

### 1. Safety Transportation

- Heavy stress, violent vibration or water splash are not allowed during transportation, storage and installation.
- This series product must use split type package during the transportation.
- We are not liable for any damage or problem resulting from the integrated package during the transportation.

### 2. When device is malfunction

Shut down the device and disconnect the power cable immediately if there is smoke, abnormal smell or abnormal function. Please contact your local retailer ASAP.

### 3. Do not try to dismantle or modify the device

- There is risk of personal injury or device damage resulting from opening the shell.
- Please contact your local retailer if there is internal setup or maintenance requirement.
- We are not liable for any problems caused by unauthorized modifications or attempted repair.

### 4. Do not allow other object falling into the device

- Please make sure there is no metal or inflammable, explosive substance in the speed dome.
- The above mentioned objects in the device may result in fire, short-circuit or damage.
- Please shut down the device and disconnect the power cable if there is water or liquid falling into the camera. Please contact your local retailer ASAP.
- Please pay attention to the camera. Avoid the sea water or rain to erode the camera.

### 5. Handle carefully

Do not allow this series product fall down to the ground.  
Avoid heavy vibration.

### 6. Installation Environment Requirement

- This series speed dome should be installed in a cool, dry place away from direct sunlight, inflammable, explosive substances and etc.
- This series product shall be away from the strong electromagnetism radiant, please keep it away from wireless power, TV transmitter, transformer and etc.

### 7. Daily Maintenance

- 
- Please use the soft cloth to clean dust on the shell, or you can use soft cloth with cleaning liquid to clean the shell and then use soft cloth to make it dry.
  - Do not use gasoline, dope thinner or other chemical material to clean the shell. It may result in shell transfiguration or paint flake.
  - Do not allow the plastic or rubber material to touch the shell for a long time. It may result in paint flake.
  - It is highly recommended to use the product with a lightning-proof device, which can realize better lightning-proof effect.



---

# 1 Installation Preparation

## 1.1 Basic Requirements

- All installation and operation here should conform to your local electrical safety codes, fire protection regulations and relevant regulations.
- Make sure if the application scenarios of speed dome conforms to the installation requirements. Please contact your local retailer if you have any confusion.
- Please use the product according to the operating environment.
- Please keep the original packing material well after opening the package, which is used to pack speed dome and send it back for repair in case problems happen.

## 1.2 Installation Check

- Please make sure the installation environment has enough space to install the speed dome and its corresponding mounting components.
- Please make sure the ceiling and wall can sustain 8X weight of the speed dome and its mounting components.
- Please make sure the wall is thick enough to install expansion bolts (Users need to purchase expansion bolts separately).
- It needs to guarantee that the mounting height has to be more than 6m if the speed dome is intelligent tracking speed dome or laser speed dome.

## 1.3 Cable Preparation

Please select video cable and lowest specification requirement of video coaxial cable according to the transmission distance.

### 1.3.1 Cable Lowest Specification Requirement

- 75 ohm.
- Full cable with copper conductor.
- 95% knitted copper shield.
- Please refer to appendix II for RS485 communication cable.

International Model	Max Transmission Distance (Ft/M)
RG59/U	750Ft/229M
RG6/U	1,000Ft/305M
RG11/U	1,500Ft/457M

#### Note

The above can be applied to analog speed dome and network speed dome.

International Model	Max Transmission Distance (MFt)
SYV-75-3	720P(25fps\30fps): 500M/1640Ft
	720P(50fps\60fps): 300M/984Ft
	1080P(25fps\30fps): 300M/984Ft

#### Note

The above can be applied to HDCVI speed dome.

---

### **1.3.2 Select Needed Power Supply Cable According to Transmission Distance**

Refer to appendix III for AC 24V power supply device.

Refer to appendix IV for DC 12V power supply device.

Refer to appendix V for DC 24V power supply device.

Refer to appendix VI for DC 36V power supply device.

Refer to appendix VII for DC48V power supply device.

---

## 2 Speed Dome Installation

### 2.1 Check Accessories

Before installation, please check the accessories one by one according to the packing list. Please make sure all the components listed are included.

### 2.2 Open the Device

Please open the box and then take out the speed dome. See Figure 2-1.

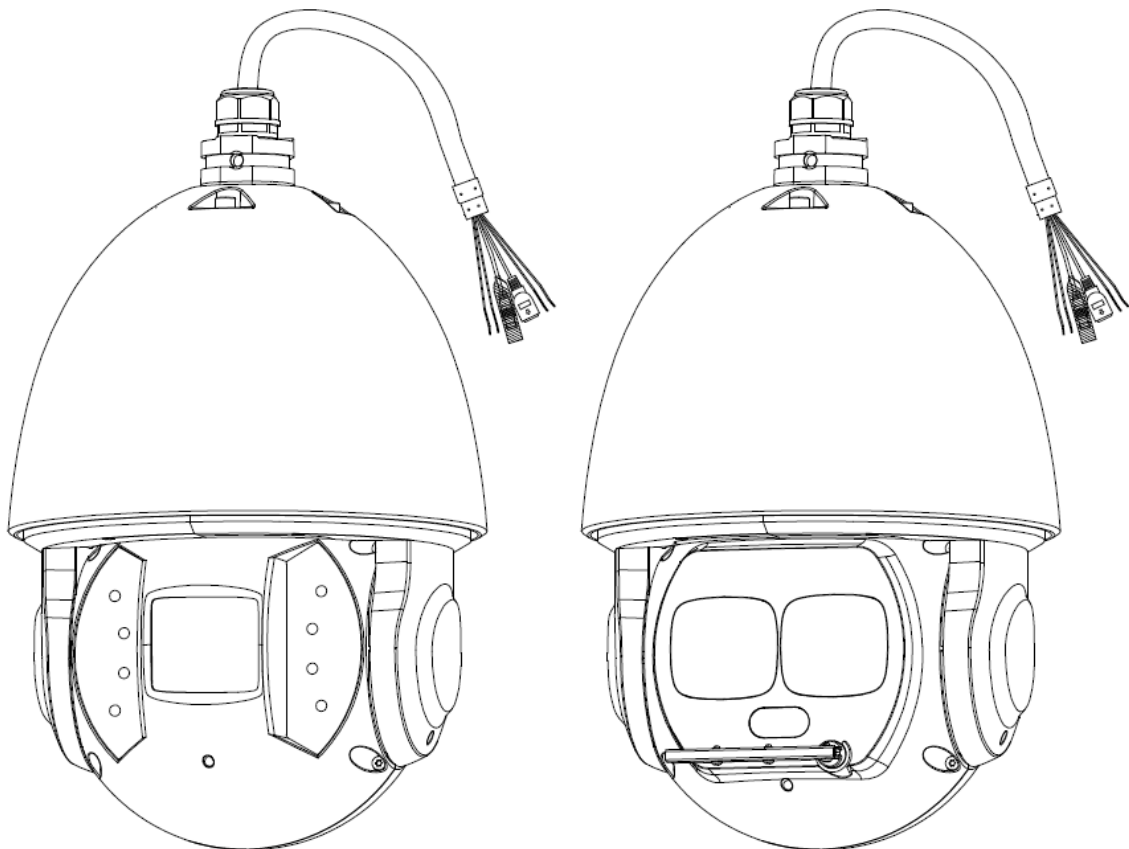

Figure 2-1

#### Note:

- There are several types of IR intelligent speed dome, please refer to the actual object for details.
- There is laser light and IR light on the laser speed dome, the laser light is used for light compensation while the IR light can be used to indicate whether the laser light is on or off, the laser light is enabled when the IR light is on.

### 2.3 DIP Switch Setup

#### 2.3.1 DIP Switch Location and Function

The corresponding functions of DIP switch for both analog speed dome and HDCVI speed dome are different, which will be introduced respectively.

### 2.3.1.1 Analog Speed Dome

Dismantle the bracket component and you can see there are two DIP switches on the PTZ mainboard. You can use them to set speed dome address, baud rate and parity. Please refer to Figure 2-2 for the location of DIP switch.

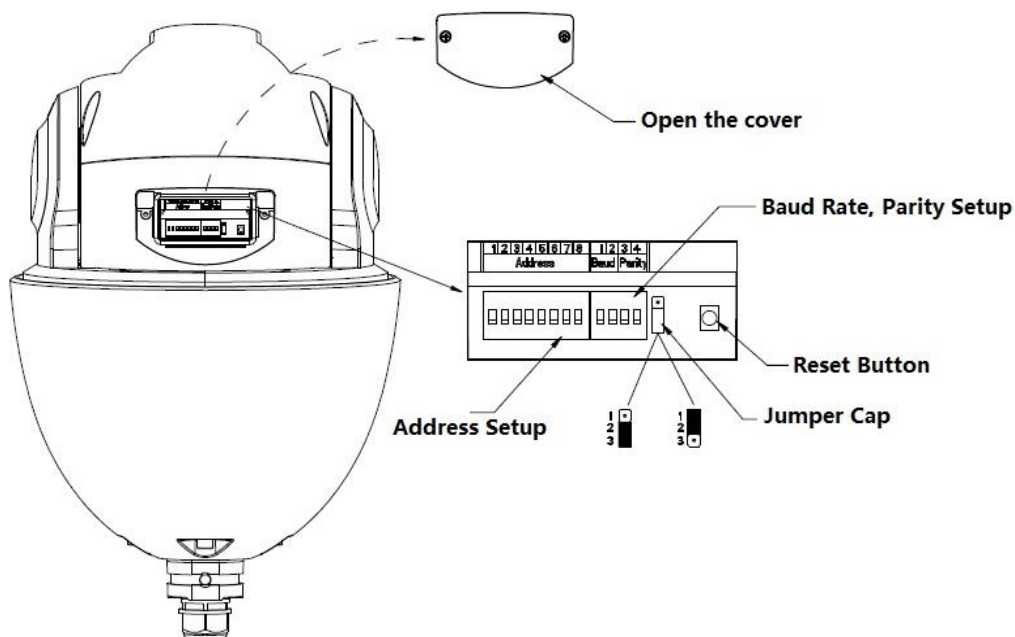

Figure 2-2

### 2.3.1.2 HDCVI Speed Dome

Dismantle the bracket component and you can see there are two DIP switches on the PTZ mainboard. You can use them to set speed dome address, baud rate and HD/SD video mode. Please refer to Figure 2-3 for the location of DIP switch.

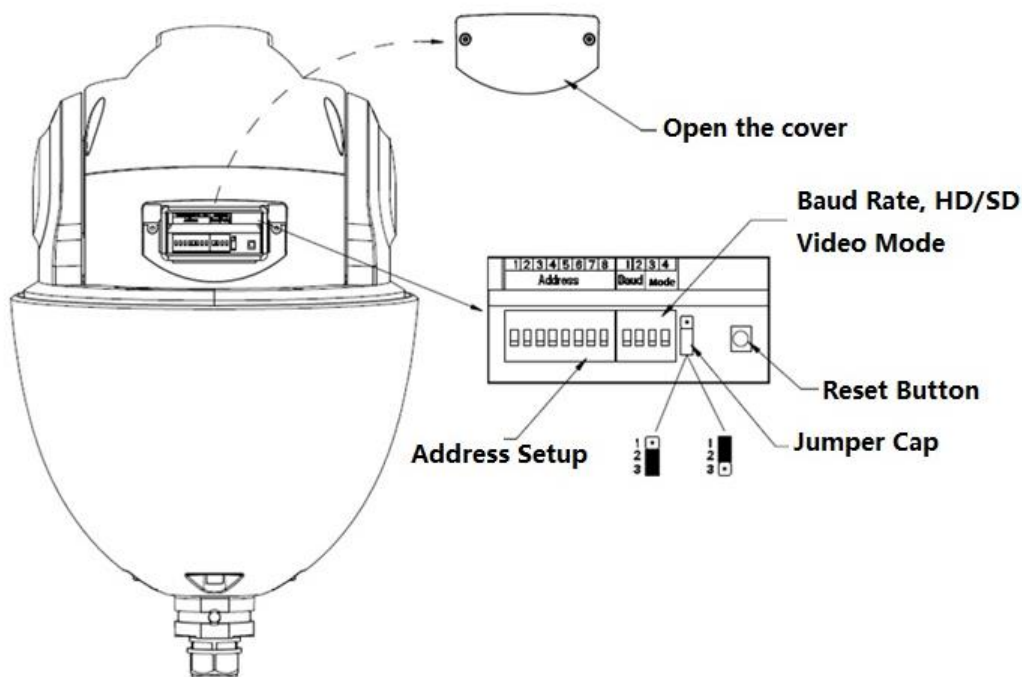

Figure 2-3

### 2.3.2 DIP Switch Setup

Users must set the address number, baud rate and parity parameters of speed dome before controlling it. Only after all these settings are completed, can the speed dome respond to its control commands.

#### Note

- As for the wall-mounted speed dome, you need to install back the transparent cover component after taking out the EPE and setting DIP switch address.
- It has to cut off the power and reboot the device after relevant info has been reset, which makes the new settings valid.

There are two DIP buttons on the speed dome PTZ which are used to confirm the speed dome address, baud rate and parity. It is 1 when you set the button as ON. For address setup DIP, 1 is the lowest bit, 8 is the highest bit; for the Baud rate and parity setup DIP, 1 is the lowest bit, 4 is the highest bit. (Intelligent speed dome self-adapt to PELCO-D, PELCO-P, industrial standard protocol, control protocol don't need DIP setup).

### 2.3.3 Address Setup

The speed dome uses DIP switch to set address, the encoding mode adopts binary system. 1 to 8 is valid bit. The highest address bit is 255; see Figure 2-4 for address label and you can refer to Table 2-1 for more information about address bit setup.

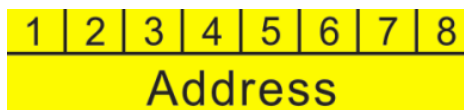

Figure 2-4

Address	1	2	3	4	5	6	7	8
0	OFF	OFF	OFF	OFF	OFF	OFF	OFF	OFF
1	ON	OFF	OFF	OFF	OFF	OFF	OFF	OFF
2	OFF	ON	OFF	OFF	OFF	OFF	OFF	OFF
3	ON	ON	OFF	OFF	OFF	OFF	OFF	OFF
4	OFF	OFF	ON	OFF	OFF	OFF	OFF	OFF
5	ON	OFF	ON	OFF	OFF	OFF	OFF	OFF
6	OFF	ON	ON	OFF	OFF	OFF	OFF	OFF
7	ON	ON	ON	OFF	OFF	OFF	OFF	OFF
8	OFF	OFF	OFF	ON	OFF	OFF	OFF	OFF
.....	.....							
254	OFF	ON	ON	ON	ON	ON	ON	ON
255	ON	ON	ON	ON	ON	ON	ON	ON

Table 2-1

### 2.3.4 Baud Rate and Parity Setup

The functions which need to be set are different for analog speed dome and HDCVI speed dome, which will be introduced respectively.

#### 2.3.4.1 Analog Speed Dome

It is used to set speed dome baud rate and parity. 1 and 2 bits are used to set baud rate while 3 and 4 bits are used to set parity, see Figure 2-5.

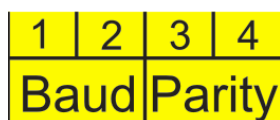

Figure 2-5

Please refer to Table 2-2 for detailed information about baud rate setup.

1	2	Baud rate
OFF	OFF	9600bps
ON	OFF	4800bps
OFF	ON	2400bps
ON	ON	1200bps

Table 2-2

Please refer to Table 2-3 for detailed information about parity setup.

3	4	Parity
OFF	OFF	NONE
ON	OFF	EVEN
OFF	ON	ODD
ON	ON	NONE

Table 2-3

#### 2.3.4.2 HDCVI Speed Dome

It is to set the speed dome baud rate. 1 and 2 bit are used to set baud rate, 3 and 4 bit are used to set HD/SD video mode. See Figure 2-6 for baud rate and mode; refer to Table 2-4 and Table 2-5 for baud rate and mode setup.

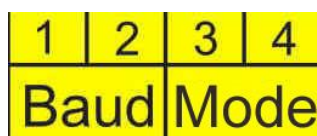

Figure 2-6

1	2	Baud rate
OFF	OFF	9600bps
ON	OFF	4800bps
OFF	ON	2400bps
ON	ON	1200bps

Table 2-4

3	4	HD/SD video mode
OFF	OFF	HD
ON	OFF	SD
OFF	ON	Self-adaptive
ON	ON	HD

Table 2-5

---

## 2.4 Terminal Matched Resistance Setup

The connection mode of device terminal 120Ω resistance is equipped on the power board. There are two connection modes which are shown in Figure 2-7.

	1-2	2-3
120 Ω	ON	OFF

Figure 2-7

The factory default connection mode is shown in Figure 2-8; the jumper (connection board) is plugged into pin2 and pin 3, which means 120Ω resistance is not connected to the device.

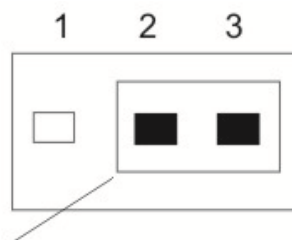

Default Jumper Setup (120Ω resistance is not connected)

Figure 2-8

If you want to connect the 120Ω resistance, you have to pull the jumper out of pin 2 and pin 3, and connect to pin 1 and pin 2, then 120Ω resistance is connected to the circuit, see Figure 2-9.

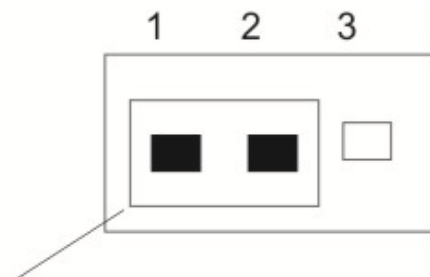

Jumper Setup (120Ω resistance is not connected)

Figure 2-9

## 2.5 Reset Button Location and SD Card Installation

You can see there is a RESET button and Micro-SD card slot on the PTZ mainboard after you open the cover. See Figure 2-10. Reset button is used to reset network system. Micro-SD card is used for data storage.

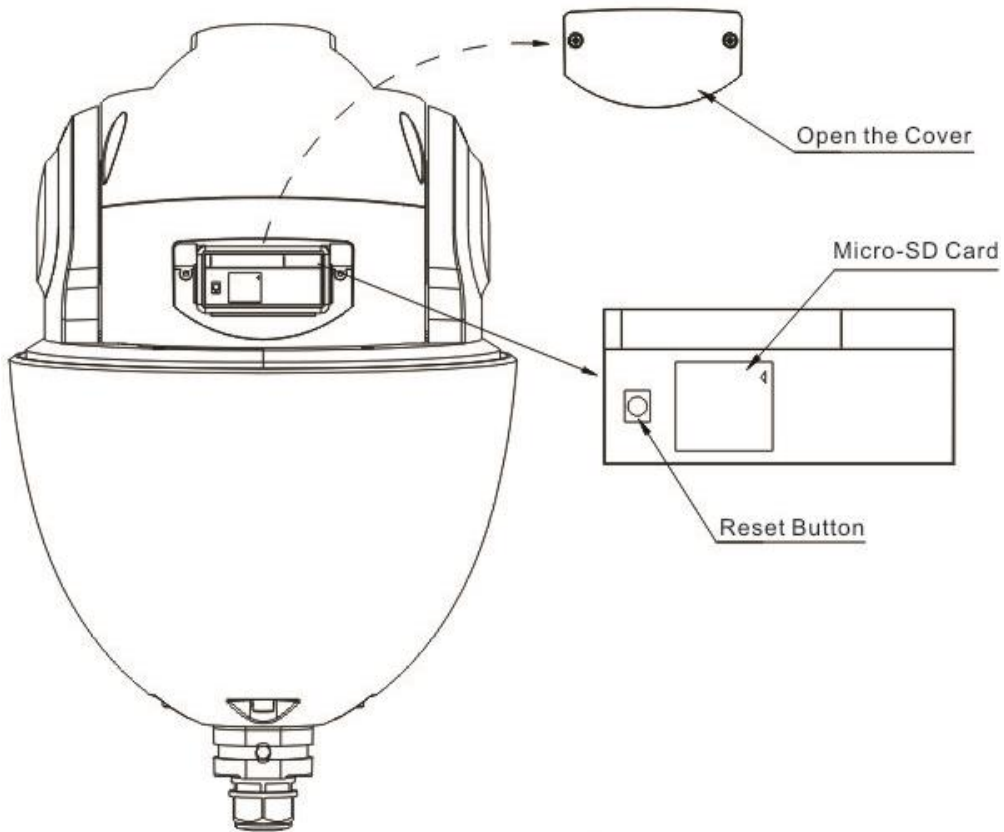

Figure 2-10

## 2.6 Speed Dome Installation

### Note

The installation of this section can be applied to IR Analog Intelligent speed dome and IR Network Intelligent Speed Dome.

The speed dome has various brackets suitable for different environments. For detailed information, please refer to chapter 3 to chapter 8. Here we are going to install the analog speed dome with the example of analog speed dome wall-mounted bracket.

### 2.6.1 Install Quick Mounting Connector

Please twine Teflon tape around the screw thread of the quick mounting connector and turn it into the screw thread of the wall-mounted bracket. Use an M4 stainless screw to secure it firmly, which is shown in Figure 2-11.



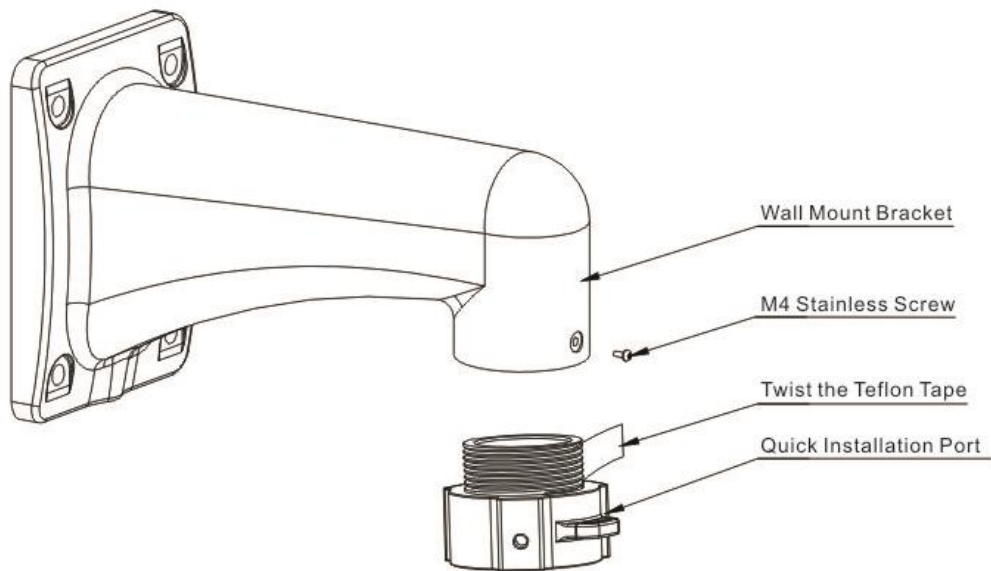

Figure 2-11

## 2.7 Speed Dome Installation

### Note

The chapter can be applied to analog intelligent speed dome and network intelligent speed dome and so on.

There are various types of brackets which can meet different application scenarios for the speed dome, please refer to chapter 3 to 8 for the installation methods. It is to take wall-mounted bracket as an example to install speed dome.

### 2.7.1 Install Quick Mount Connector

Twine Teflon tape over the thread of quick mount connector and rotate it into the pipe thread of wall-mounted bracket, use M4 stainless screw to fix it firmly, which is shown in Figure 2-12, the thread standard is G1 1/2 pipe thread.

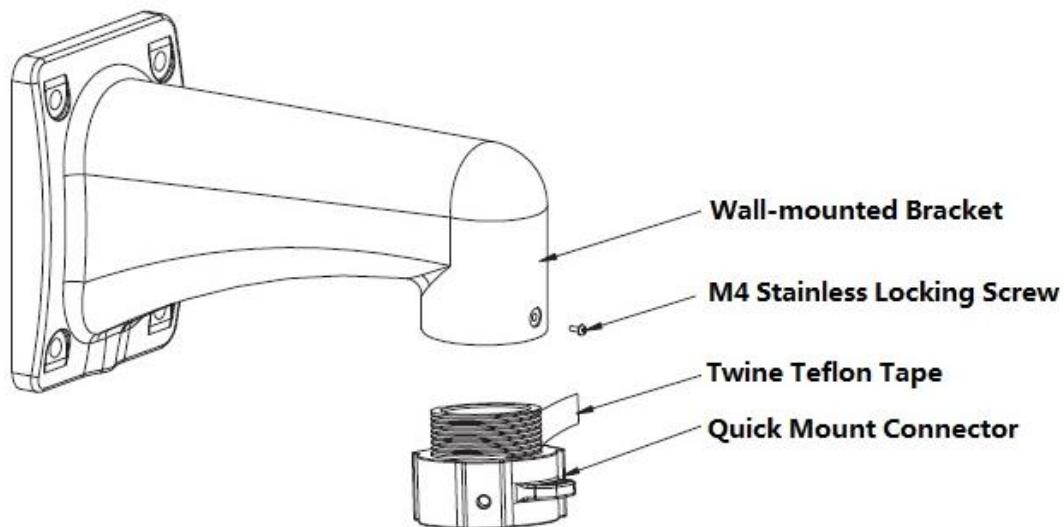

Figure 2-12

## 2.7.2 Speed Dome Cable

### 2.7.2.1 Cable Description

The camera is equipped with a multi-functional combination cable by default, which includes power cable, video cable, audio cable, RS485 control cable, alarm cable, network cable, high-frequency cable and optical fiber cable etc. The cable detail is shown in Figure 2-13.

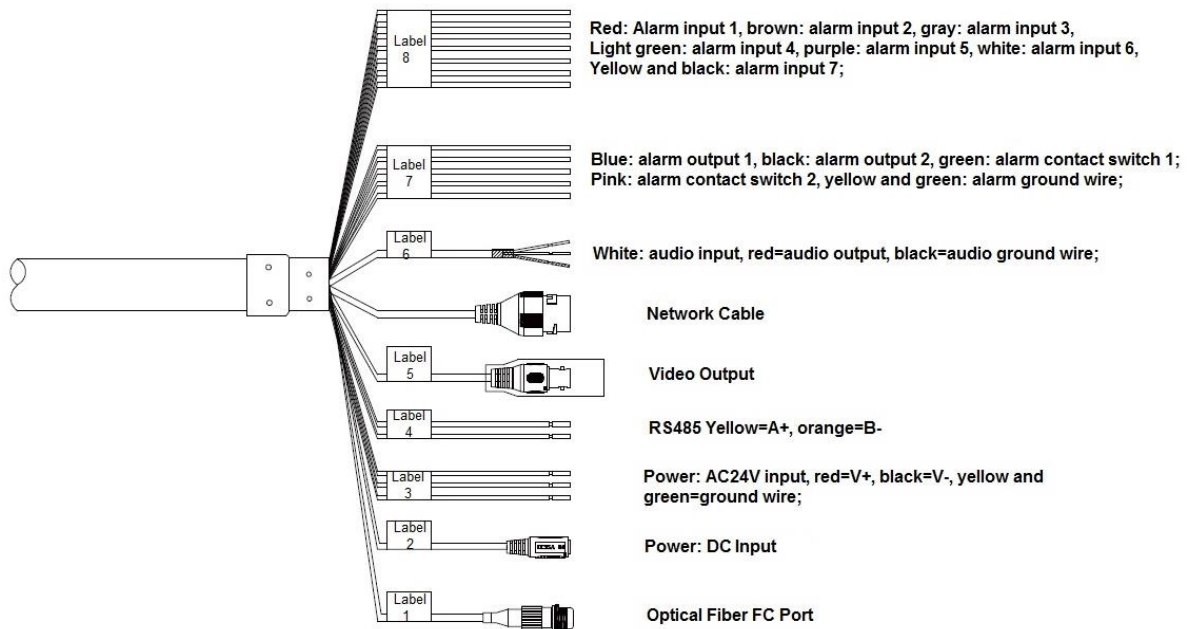

Figure 2-13

#### Note

Different models have different cable combinations; please refer to the actual cable combination for more details. The cable combination is the most comprehensive example shown in the figure above.

It is prohibited to pull the cable to lift the speed dome when moving the device, the wrong way of carrying device is shown in Figure 2-14.

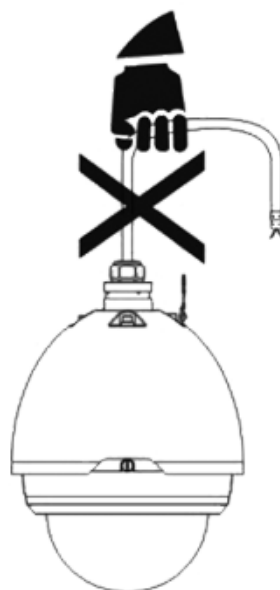

Figure 2-14

### 2.7.2.2 Cable Connection

Buckle the safety hook of speed dome on the quick mount connector; connect the integrated cable reserved by wall-mounted bracket to the corresponding power cable, video cable, audio cable, RS485 control cable, alarm cable, network cable, high-frequency cable and optical fiber cable etc. of the multi-functional combination cable of the speed dome (according to requirement), and then use insulated rubber tape to twine the cable connection well to make it waterproof. Refer to Figure 2-15 for more details.

#### Note

During actual installation, make sure the wire diameter of the cable which is to connect to RS485 control cable can't be too big; otherwise it will affect the control effect. Please refer to appendix II RS485 bus for relevant introduction.

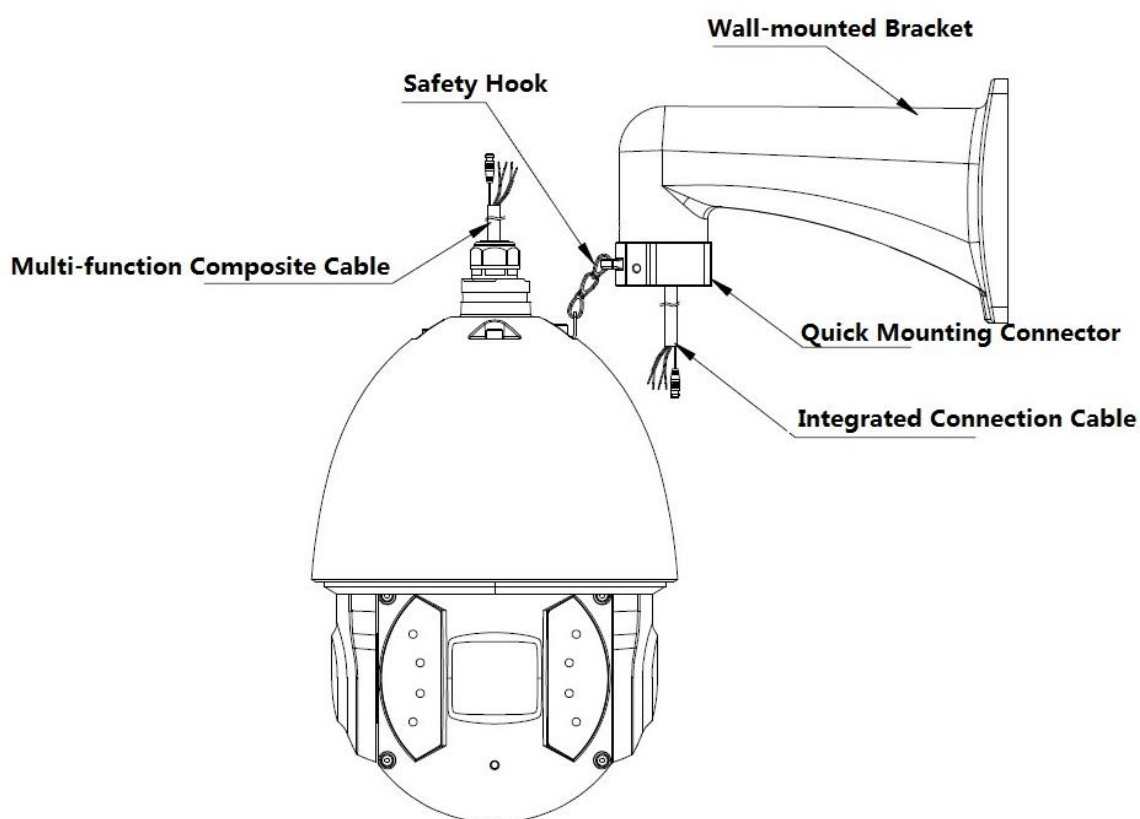

Figure 2-15

### 2.7.2.3 Alarm Cable Connection

The alarm cable connection mode and config steps are shown as follows:

#### Step 1

Connect alarm input device to the ALARM\_IN and ALARM\_GND of the user cable.

#### Step 2

Connect alarm output device to the ALARM\_OUT and ALARM\_COM of the user cable, alarm output is the relay switch output.

#### Step 3

Open the device WEB interface, make corresponding settings to the alarm input and output device in "Setup > Event > Alarm Setup". The alarm input of WEB is corresponding to the alarm

input of the user cable. It is to set the corresponding NO and NC output according to the high and low level signal generated by alarm input device when alarm triggers.

#### Step 4

Set the alarm output situation of user cable on the WEB.

#### 2.7.2.4 Connect Speed Dome GND Cable

Connect the power line YELLOW/GREEN of the combination cable to the lightning protection device, and make sure the lightning protection device is well grounded.

### 2.7.3 Install the speed dome

#### Step 1

Pull the integration cable and multiple-function composite cable to the wall mount bracket slowly.

#### Step 2

Line up the straight edge of the flange of the IR speed dome to the straight edge of the quick installation port, and then push the speed dome to the bottom of the port slowly.

#### Step 3

Use your hands to turn the M6\*14 stainless screw (with spring washer) to the  $\Phi 6.5$  hole of the straight edge of the IR speed dome. Turn other two M6\*14 stainless screws to groove of IR speed dome flange. Use the inner hex tool to fix these three stainless screws. Now you have completed the installation. See Figure 2-16.

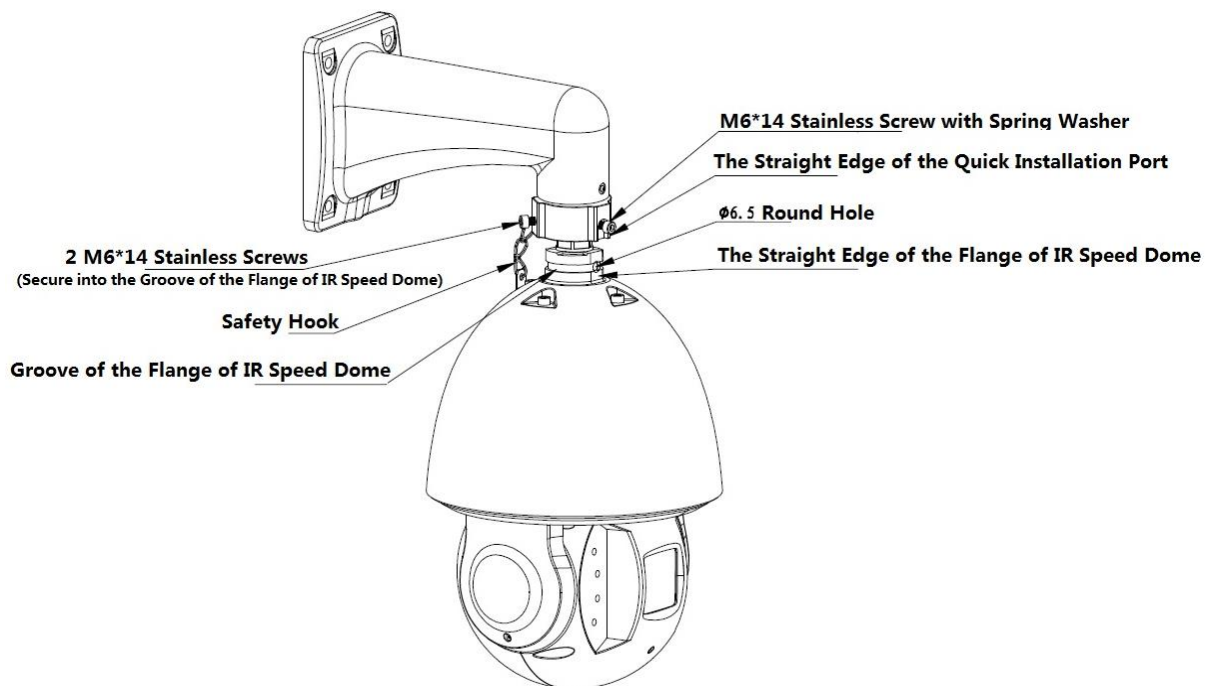

Figure 2-16

#### Step 4

Please make sure:

- The three stainless screws of the quick installation port are firmly secure.
- The IR speed dome is fixed.
- The speed dome is straight.
- The steel wire connection is firm.

---

After your installation, the interface is shown as in Figure 2-17.

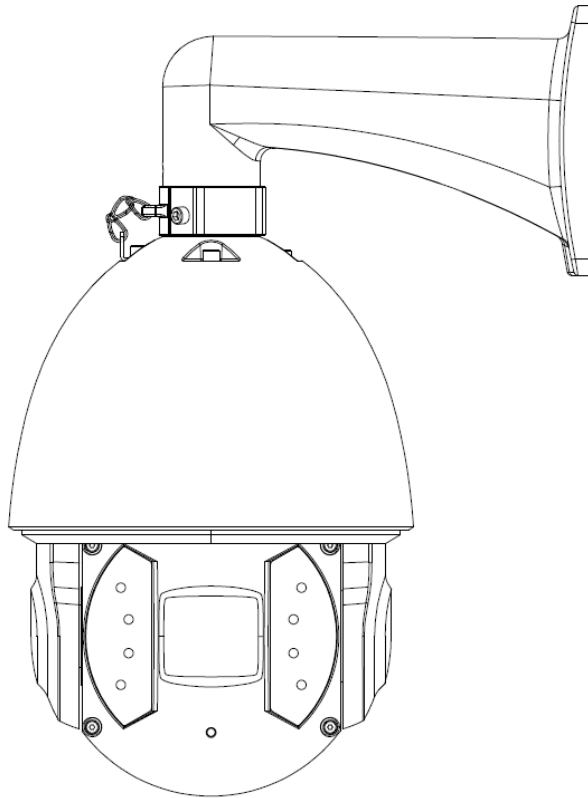

Figure 2-17

---

### 3 Wall-mounted Bracket Installation

#### 3.1 Mounting Component and Dimension

The wall-mounted bracket is shown in Figure 3-1, the dimension is shown in Figure 3-2, the dimension of adapter block is shown in Figure 3-3.

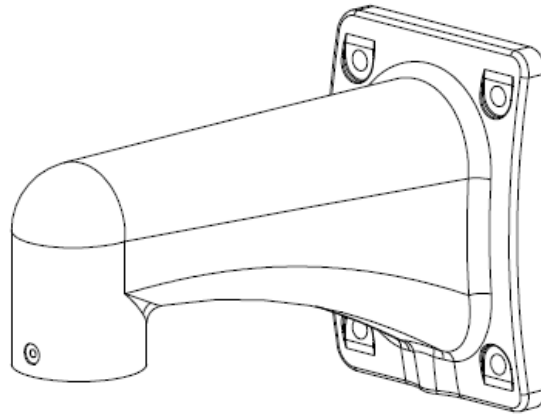

Figure 3-1

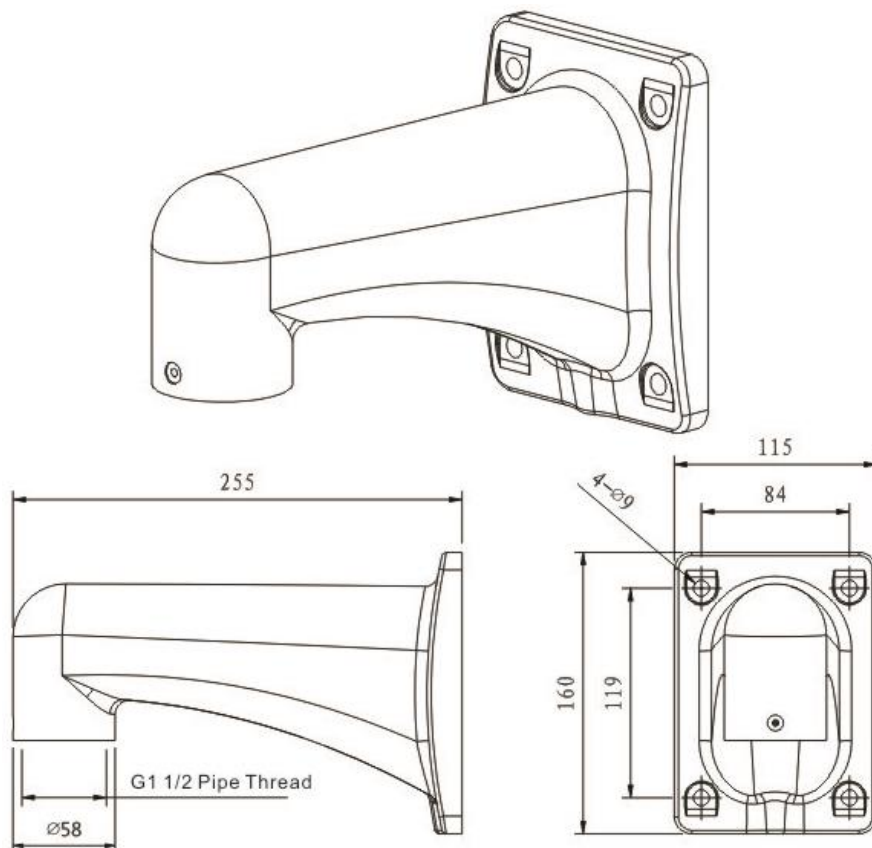

Figure 3-2

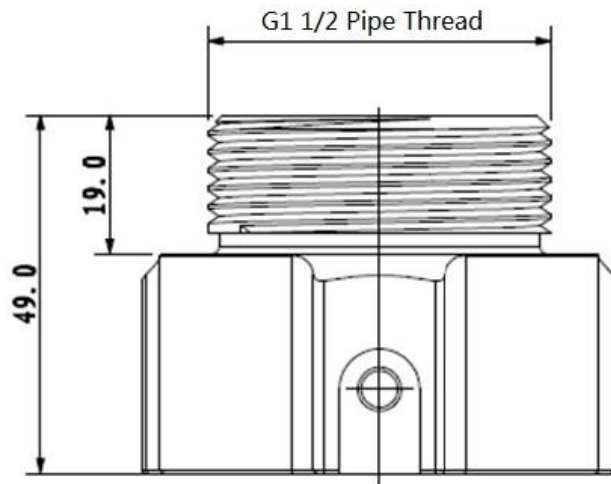

Figure 3-3

## 3.2 Wall-mounted Bracket Installation Steps

### 3.2.1 Installation Conditions

Wall-mounted speed dome can be installed on hard wall structure in both indoor and outdoor environments. The wall needs to meet the following installation conditions:

- The wall shall be thick enough to install expansion bolts.
- The wall needs to sustain at least 8X weight of the camera and bracket etc.

### 3.2.2 Installation Steps

#### Step 1

As it is shown in Figure 3-4, take the mounting hole of wall-mounted bracket bottom as template, draw punching position on the wall and dig holes, then insert the expansion bolts into the holes you just dug (users need to prepare expansion bolts by themselves). Use 4 hex nuts and flat gasket to twist wall-mounted bracket into the expansion bolts which have been inserted.

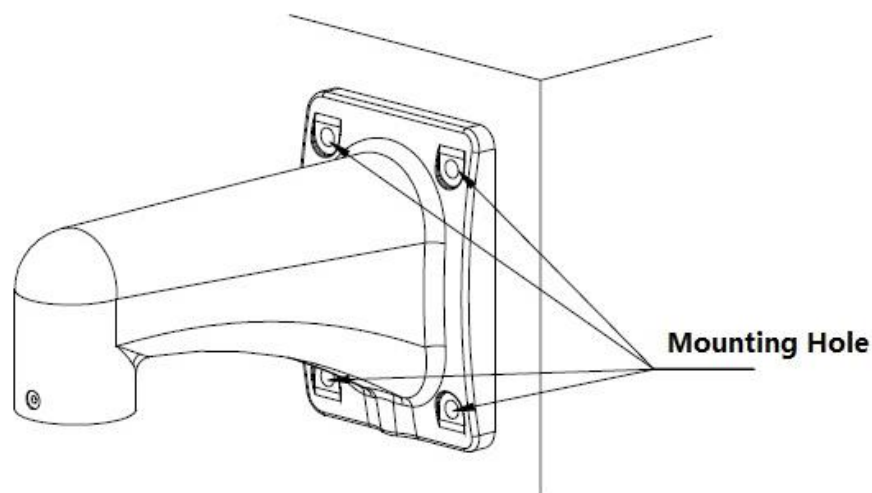

Figure 3-4

---

**Step 2**

Install the intelligent speed dome on the wall-mounted bracket, which is shown in Figure 3-5. Refer to “2.7 Speed Dome Installation” for the installation mode of speed dome.

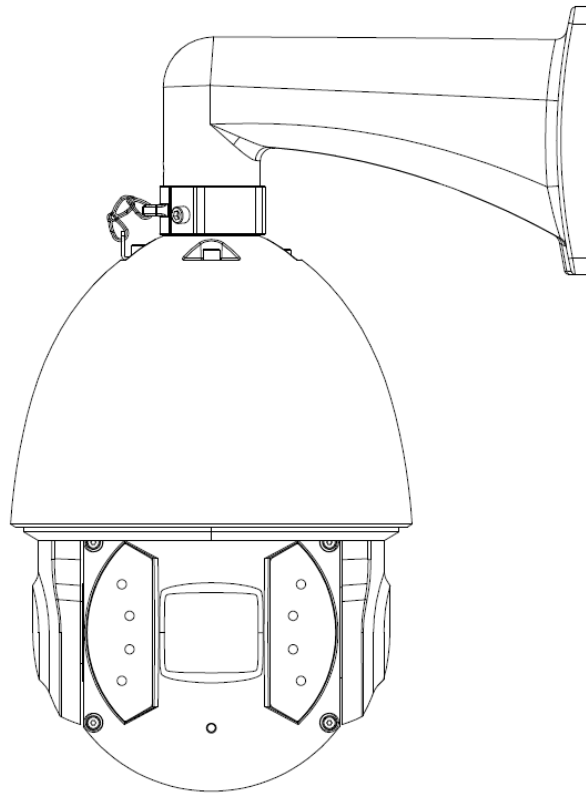

Figure 3-5



## 4 Hang-mounted Bracket Installation

### 4.1 Mounting Component and Dimension

The hang-mounted bracket is shown in Figure 4-1, the dimension is shown in Figure 4-2.

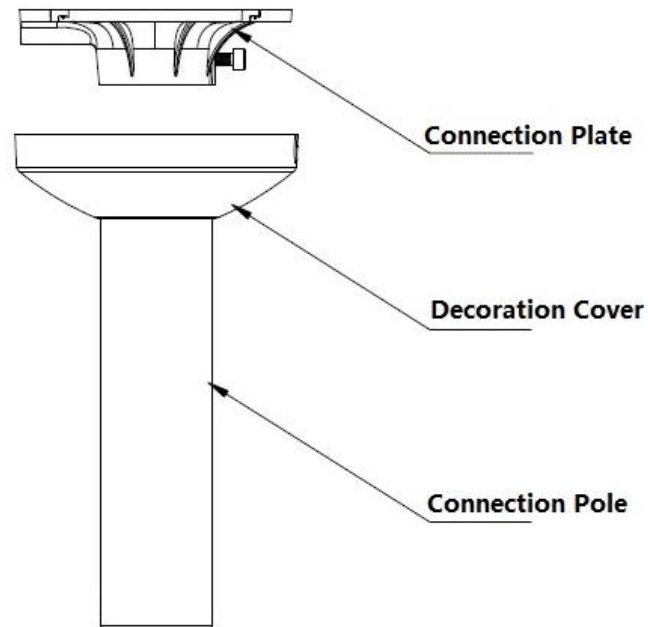

Figure 4-1

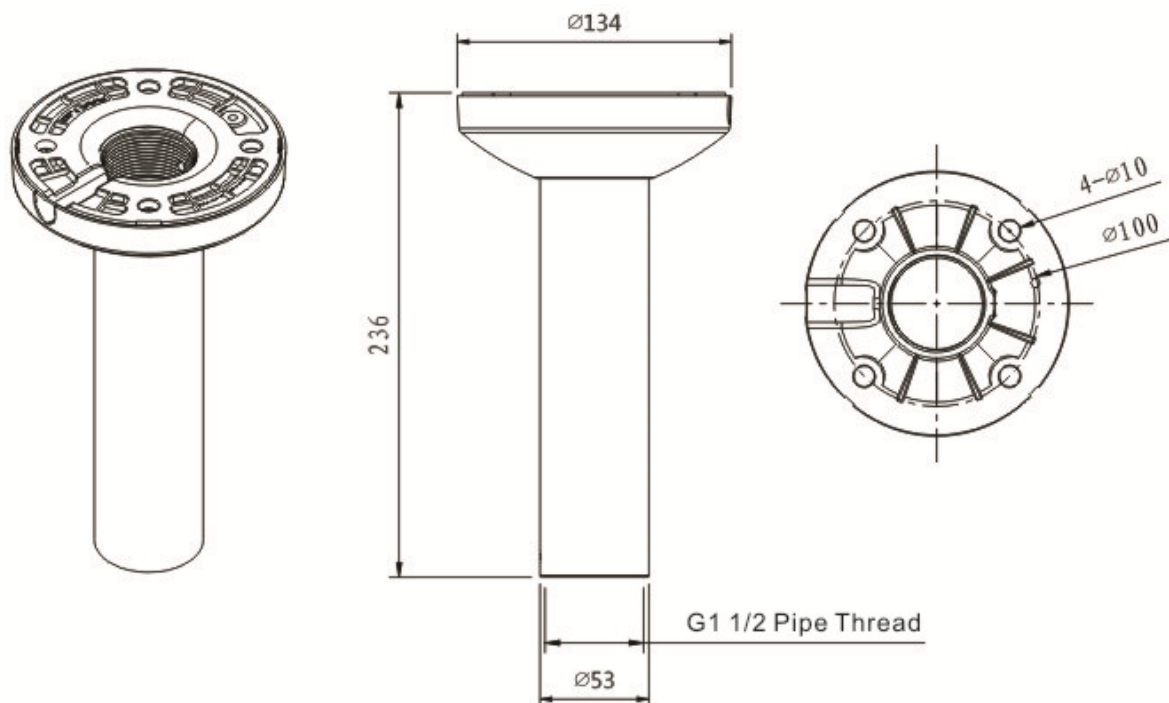

Figure 4-2

#### Note

The adjustment range of bracket length is 200mm by default, 400mm optional. It only needs to replace the connection pole.

---

## 4.2 Hang-mounted Bracket Installation Steps

### 4.2.1 Installation Conditions

Hang-mounted speed dome can be installed on hard wall structure in both indoor and outdoor environments. The wall needs to meet the following installation conditions:

- The wall shall be thick enough to install expansion bolts.
- The wall needs to sustain at least 8X weight of the camera and bracket etc.

### 4.2.2 Installation Steps

#### Step 1

As it is shown in Figure 4-3, first loosen the M4 screw on the lateral of connection plate, separate connection plate from the connection pole, and then lead in the composite cable from seal groove which is located on the bottom lateral notch of the connection plate and pull it through the center hole which is connected to flange. Fix the connection plate on the ceiling.

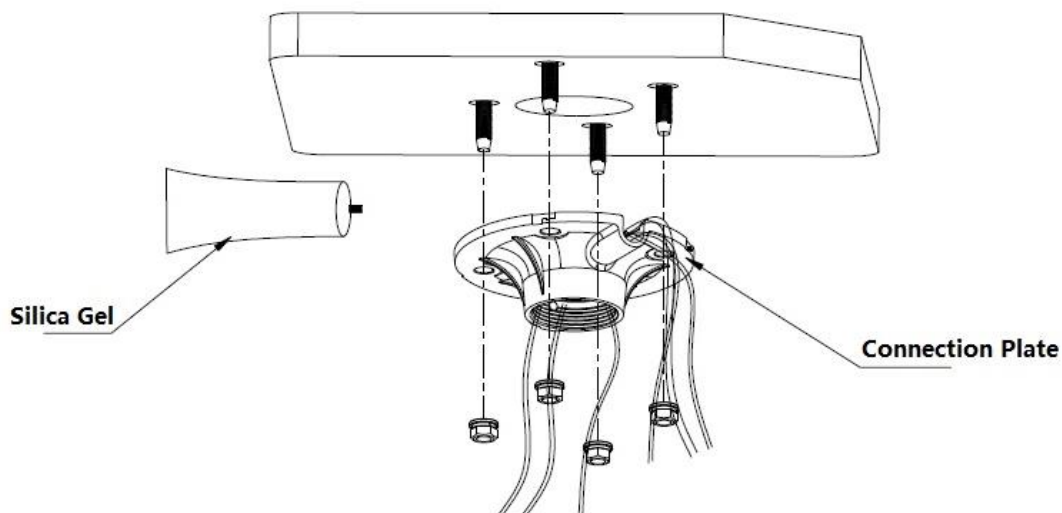

Figure 4-3

#### Note

It needs to use silica gel to cover the contact surface between connection plate and ceiling, cable outlet area to make it sealed and waterproof if the speed dome is used outdoors.

#### Step 2

As it is shown in Figure 4-4, pull the cable through connection pole, rotate the connection pole to the connection plate and tighten M4 screw firmly, then push the decoration cover to the bottom.

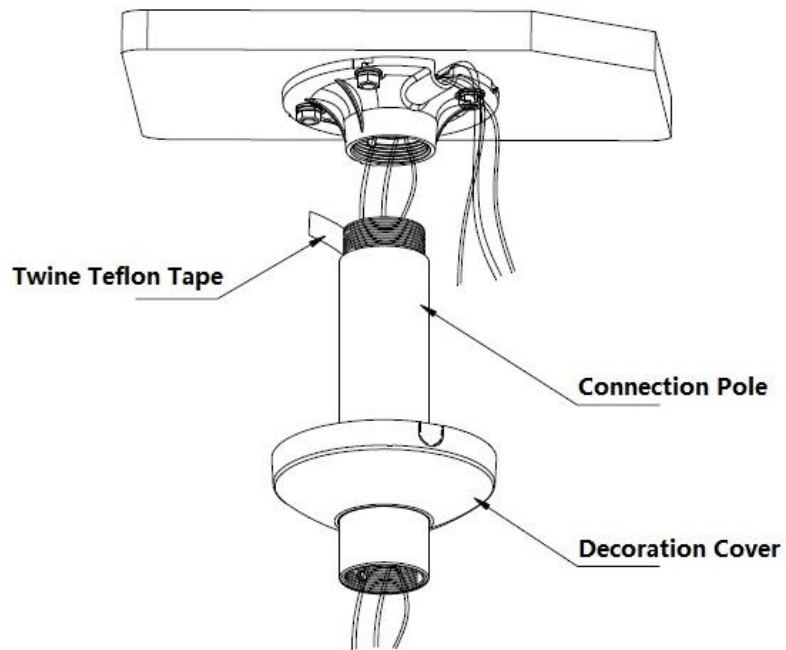

Figure 4-4

**Note**

It needs to twine enough Teflon tape on the thread of upper part of connection pole and then twist the connection pole firmly to the connection plate.

**Step 3**

Install the speed dome, which is shown in Figure 4-5. Please refer to “2.7 Speed Dome Installation” for exact installation mode.

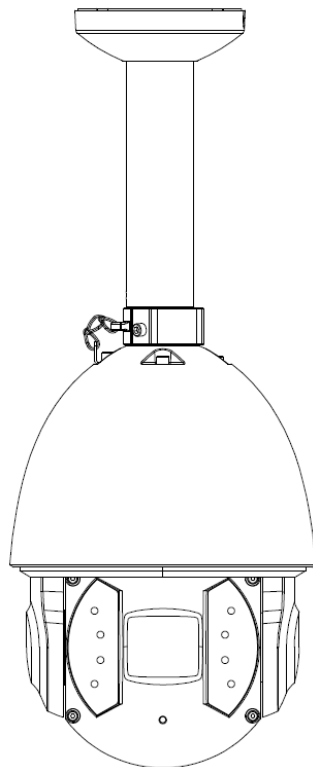

Figure 4-5

## 5 Corner-mounted Bracket Installation

### 5.1 Mounting Component and Dimension

The corner-mounted bracket is shown in Figure 5-1, the dimension is shown in Figure 5-2.

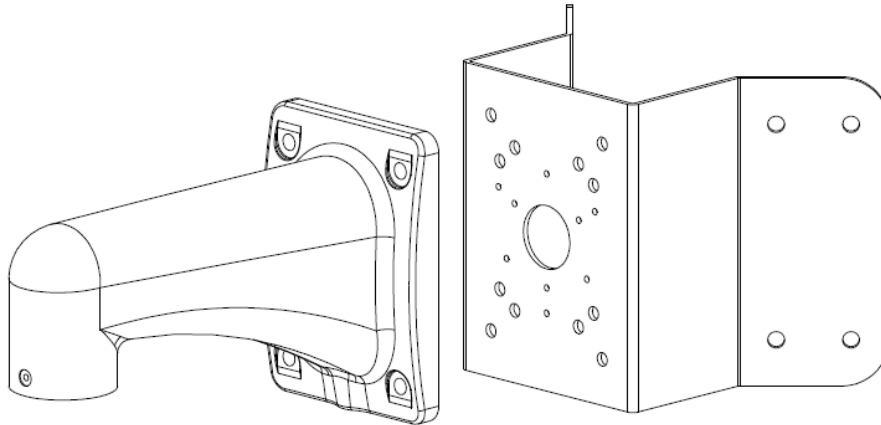

Figure 5-1

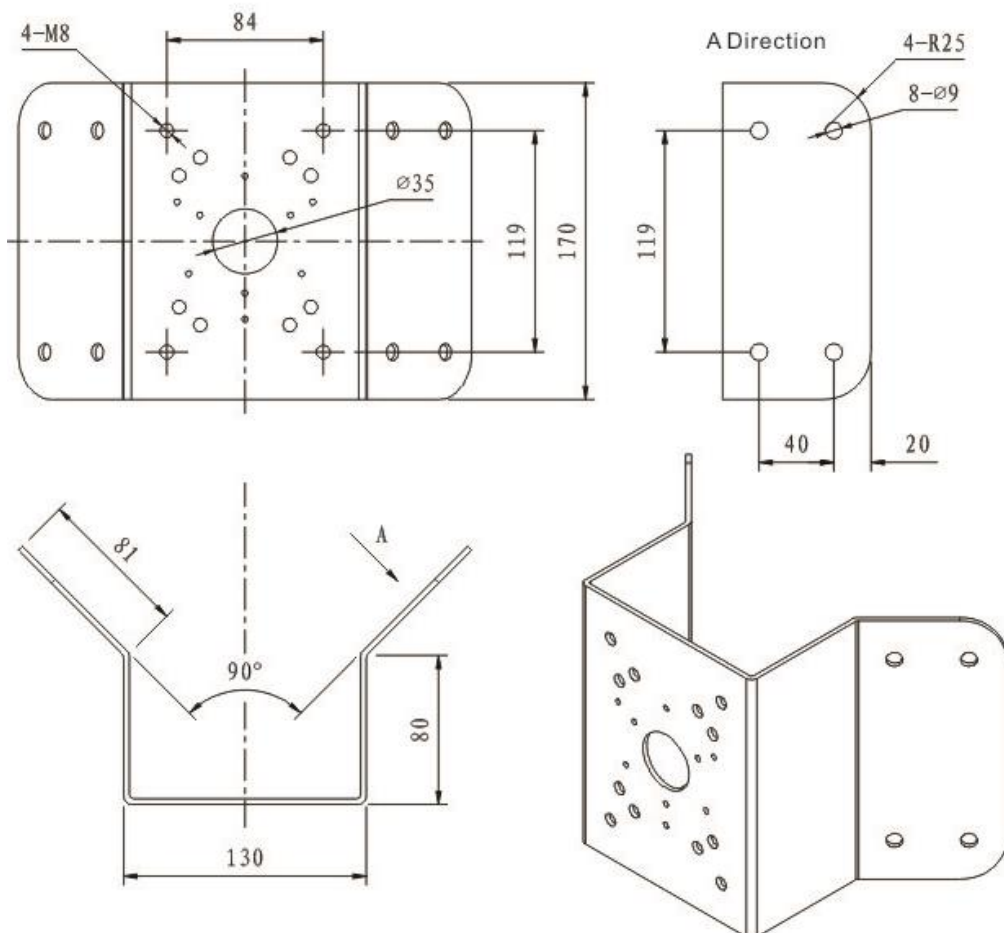

Figure 5-2

---

## 5.2 Corner-mounted Bracket Installation Steps

### 5.2.1 Installation Conditions

Corner-mounted speed dome can be installed on hard wall structure which forms an included angle of 90° in both indoor and outdoor environments. The wall needs to meet the following installation conditions:

- The wall shall be thick enough to install expansion bolts.
- The wall needs to sustain at least 8X weight of the camera and bracket etc.

### 5.2.2 Installation Steps

#### Step 1

AS it is shown in Figure 5-3, take the mounting hole of corner-mounted accessory as template, draw punching position on the wall with 90° included angle and install M8 expansion bolt. Pull the integrated cable through the center hole of corner-mounted pedestal, leave enough wiring length and use M8 nut to fasten corner-mounted pedestal on the wall firmly, and then use silicon sealant to cover cable outlet and make it waterproof.

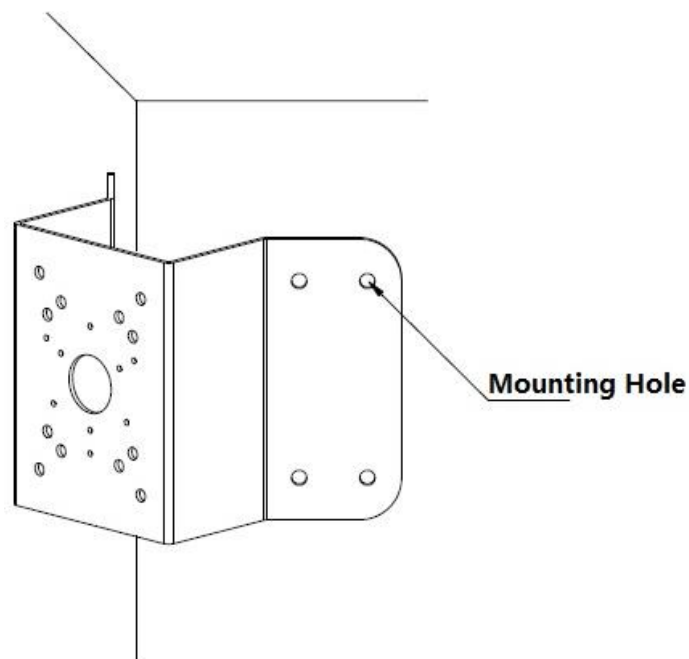

Figure 5-3

#### Step 2

Install speed dome, as it is shown in Figure 5-4; please refer to “2.7 Speed Dome Installation” for exact installation modes.

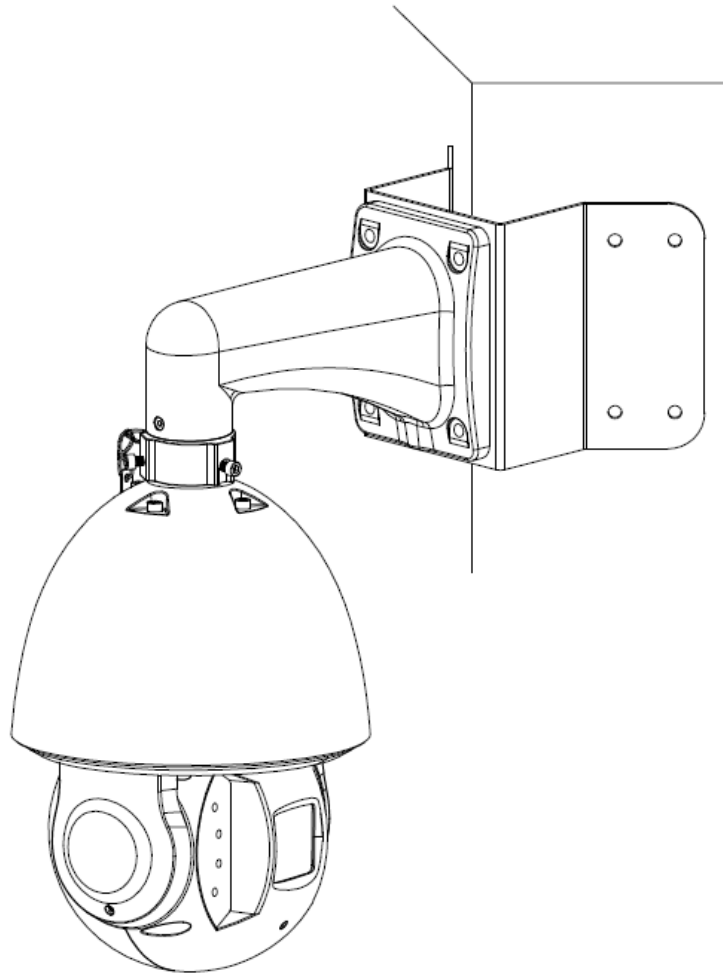

Figure 5-4

## 6 Pole-Mounted Bracket Installation

### 6.1 Mounting Component and Dimension

The pole-mounted bracket is shown in Figure 6-1, the dimension is shown in Figure 6-2.

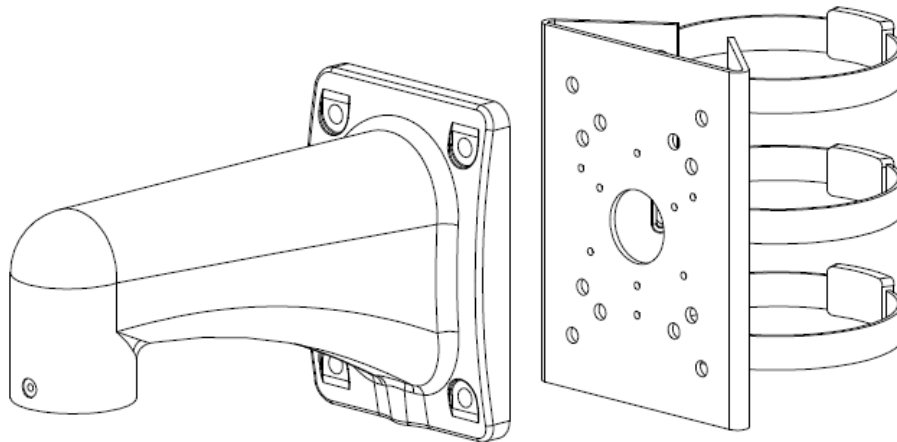

Figure 6-1

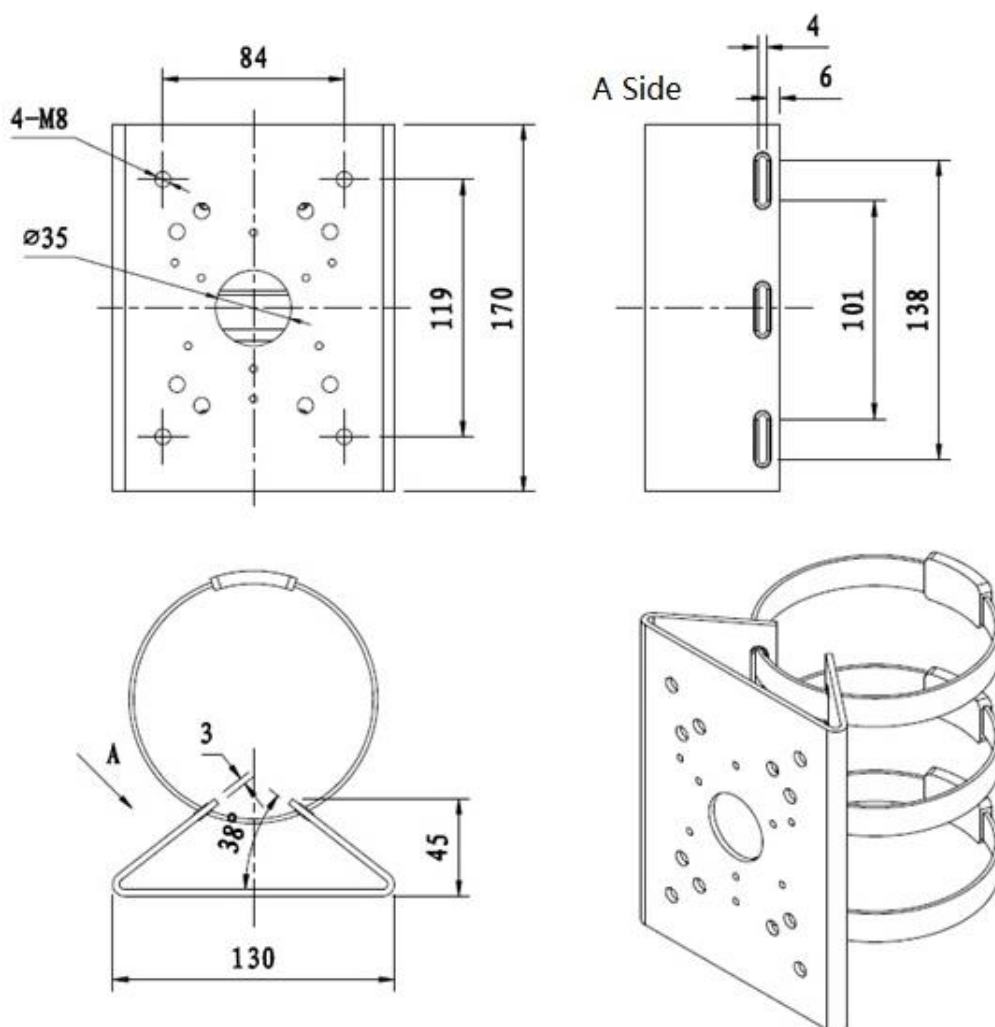

Figure 6-2

---

## 6.2 Pole-mounted Bracket Installation Steps

### 6.2.1 Installation Conditions

Pole-mounted speed dome can be installed on hard pole-shaped structure in both indoor and outdoor environments. The wall needs to meet the following installation conditions:

- The diameter of the pole structure shall comply with the installation dimension of the clamp.

Default factory hoop is 5 inches for the pole of  $\phi 80-130\text{mm}$ . It can work with the pole-

mounted bracket. You can adjust the diameter and the value (hoop specification) is :  $\phi 59-$

$82\text{mm}$ ,  $\phi 84-108\text{mm}$ ,  $\phi 80-130\text{mm}$ ,  $\phi 130-152\text{mm}$ ,  $\phi 155-178\text{mm}$ ,  $\phi 180-203\text{mm}$  and  $\phi 194-$

$216\text{mm}$ . It is optional according to customers' requirements; special dimension can be customized as well.

- The pole-mounted structure needs to sustain at least 8X weight of the camera and bracket etc.

### 6.2.2 Installation Steps

#### Step 1

As it is shown in Figure 6-3, it is to install hoop and pole-mounted bracket. Pull the cable out of the pole accessories and then use hoop to fix the accessories to the pole firmly. Finally, you can use silicon sealant to cover the cable outlet and make it waterproof.

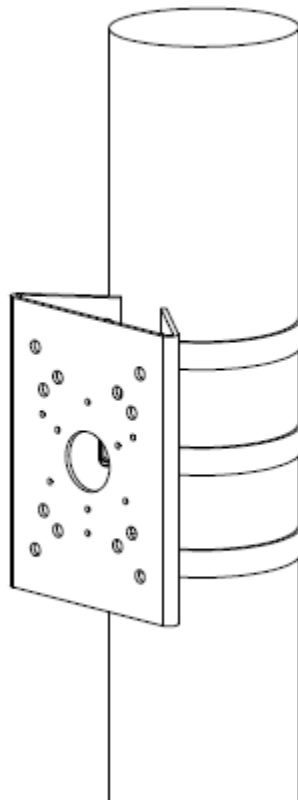

Figure 6-3



---

**Note**

Please check if the hoop is firmly fastened after installation, it may result in hoop breakage if it is not properly installed.

**Step 2**

Install speed dome, it is shown in Figure 6-4; please refer to “2.7 Speed Dome Installation” for exact installation mode.

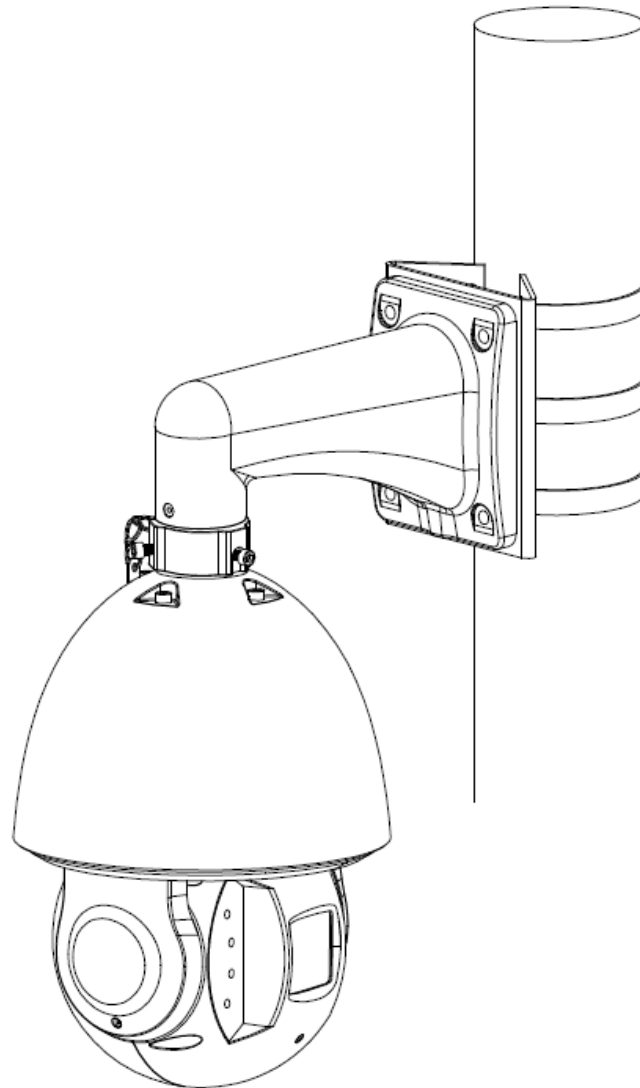

Figure 6-4

# 7 APPENDIX I LIGHTNING PROOF AND SURGE PROTECTION

## 7.1 Outdoors

This series speed dome adopts TVS lightning protection technology. It can effectively prevent damages from various pulse signals below 6000V, such as sudden lightning and surge. While maintaining your local electrical safety code, you still need to take necessary precaution measures when installing the speed dome in the outdoor environment.

- The distance between the signal transmission cable and high-voltage device (or high-voltage cable) shall be at least 50 meters.
- Outdoor cable layout shall go under the penthouse if possible.
- For vast land, please use sealing steel tube under the land to implement cable layout and connects one point to the earth. Open floor cable layout is forbidden.
- In area of strong thunderstorm hit or near high sensitive voltage (such as near high-voltage transformer substation), you need to install additional high-power thunder protection device or lightning rod.
- The thunder protection and earth of the outdoor device and cable shall be considered in the building whole thunder protection and conform to your local national or industry standard.
- System shall adopt equal-potential wiring. The earth device shall meet anti-jamming and at the same time conforms to your local electrical safety code. The earth device shall not short circuit to N (neutral) line of high voltage power grid or mixed with other wires. When connect the system to the earth alone, the earth resistance shall not be more than  $4\ \Omega$  and earth cable cross-sectional area shall be no less than  $25\ \text{mm}^2$ . See Figure 7-1.

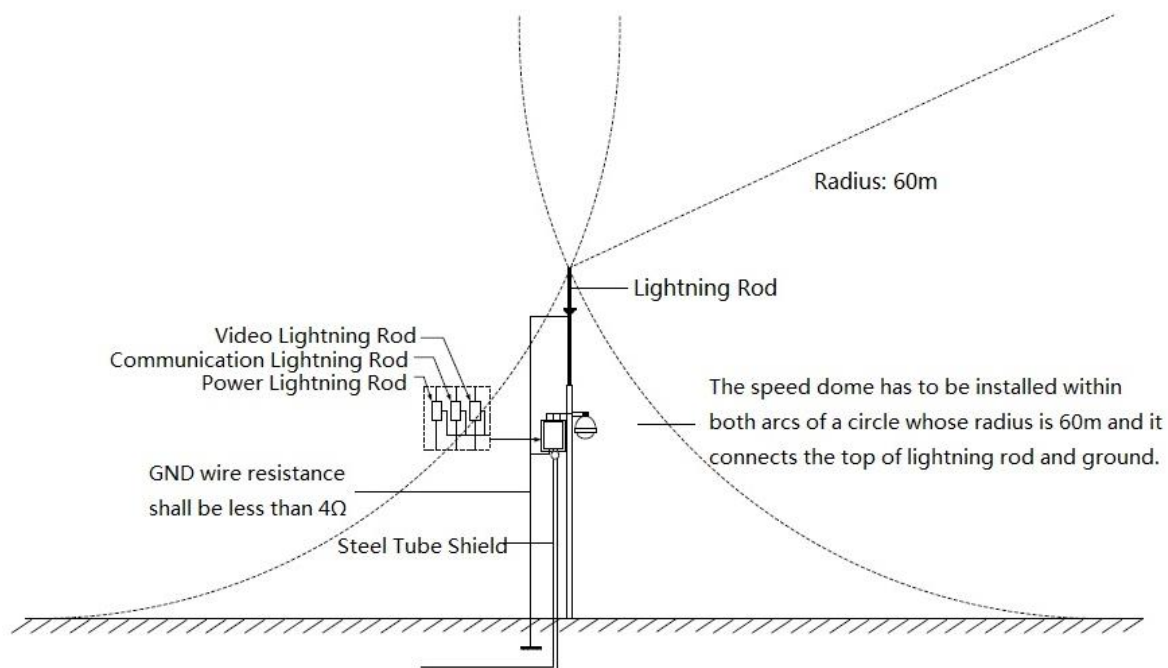

Figure 7-1

---

## 7.2 Indoors

The yellow and green GND wire or GND screw of the speed dome should be reliably connected by several strands of copper wire with no less than 25mm<sup>2</sup> and indoor equipotential GND terminal. Please refer to Figure 7-2 for lightningproof installation mode.

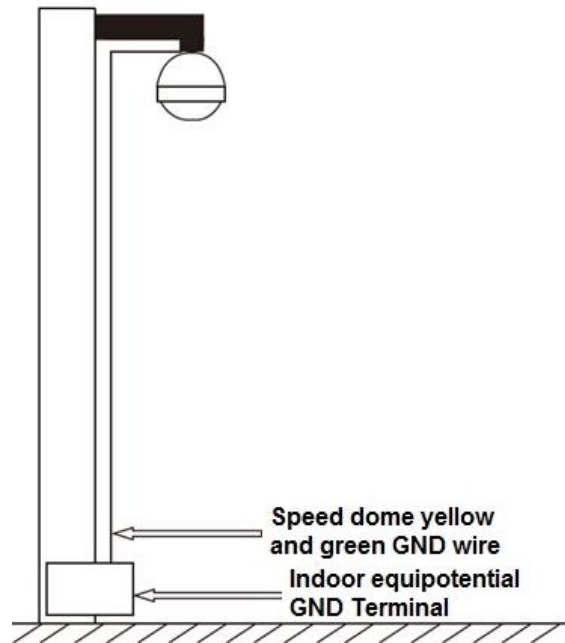

Figure 7-2

---

## 8 APPENDIX II ABOUT RS485 BUS

### 8.1 RS485 Bus Main Feature

RS485 is semi duplex communication cable of impedance  $120\ \Omega$  . Its max load amount is 32 effective loads (including main control device and devices to be charged).

### 8.2 RS485 Bus Transmission Distance

When we take 0.56mm (24AWG) twisted-pair as communication cable, the max transmission distance (theoretically) are listed below (according to different baud rates).

Baud Rate	Max Distance
2400 BPS	1800M
4800 BPS	1200M
9600 BPS	800M

In the following situations, the max transmission distance shall become shorter accordingly:

- The communication cable is a little bit thin;
- The surrounding environment has strong electromagnetic interference;
- There are too much devices connected to the RS485 bus;

And vice versa, the max transmission distance shall become longer.

### 8.3 The Problem in Practical Use

In practical usage, we usually adopt star type connection. The terminal resistance shall connect to the furthest two devices (Such as device 1# and device 15# in Figure 8-1 ). But this connection way does not conform to RS485 Bus standard. When the distances between devices are too long, the signal reflection occurs and anti-jamming decreases, thus the signal reliability becomes very low. You can see speed dome is not under control or speed dome is running automatically and cannot stop.

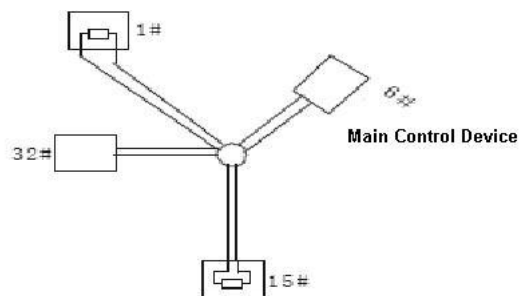

Figure 8-1

In this situation, we recommend RS485 distributor. This device can turn star type connection into the connection that conforms to RS485 bus industry standard, which can avoid the above mentioned problems and enhance communication reliability. See Figure 8-2.

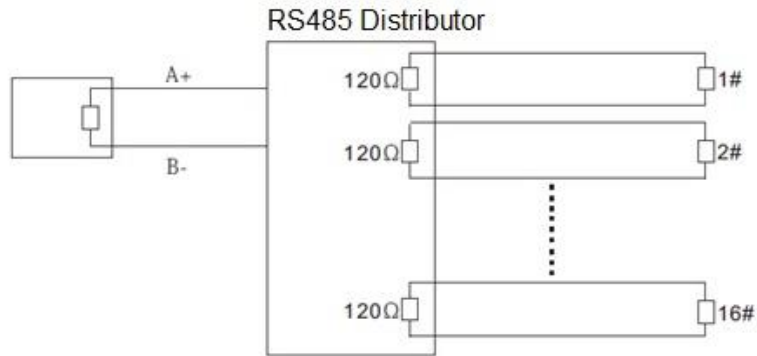

Figure 8-2

## 8.4 RS485 Bus FAQ

Phenomenon	Possible Reasons	Solution
Speed dome can run self-diagnosis but I cannot control it.	<ul style="list-style-type: none"> <li>● Host address(baud rate) and speed dome address(baud rate) are not match;</li> <li>● Positive and negative end of RS485 Bus are misconnected;</li> <li>● Connection cable is loose;</li> <li>● RS485 Bus connection are cut off;</li> </ul>	<ul style="list-style-type: none"> <li>● Modify host or speed dome setup ;</li> <li>● Switch RS485 positive end and negative end;</li> <li>● Fix connection cable firmly;</li> <li>● Replace RS485 Bus.</li> </ul>
I can control the speed dome but is not smooth	<ul style="list-style-type: none"> <li>● RS485 Bus connection are not good;</li> <li>● One RS485 bus is off;</li> <li>● The distance between host and speed dome is too far;</li> <li>● Parallel connected too much speed domes.</li> </ul>	<ul style="list-style-type: none"> <li>● Connect RS 485 Bus again;</li> <li>● Replace RS485 Bus;</li> <li>● Add terminal matching resistance;</li> <li>● Add RS485 distributor.</li> </ul>

## 9 APPENDIX III THE RELATIONSHIP BETWEEN AC 24V CABLE DIAMETER AND TRANSMISSION DISTANCE

It is the recommended transmission distance when the cable diameter is fixed and the AC 24V power consumption is below 10%. For the AC device, the max permission voltage power consumption is 10%. For example, when a device of rated power 20W installed from the transformer 141 inches (42m), then the min cable diameter is 0.8000mm.

Feet (m) w	mm			
	0.8000	1.000	1.250	2.000
5	488.52 (148.90)	763.31 (232.66)	1192.67 (363.53)	3053.25 (930.63)
10	244.26 (74.45)	381.66 (116.33)	596.34 (181.76)	1526.62 (465.31)
15	162.84 (49.63)	254.44 (77.55)	397.56 (121.18)	1017.75 (310.21)
20	122.13 (37.23)	190.83 (58.16)	298.17 (90.88)	763.31 (232.66)
25	97.70 (29.78)	152.66 (46.53)	238.53 (72.71)	610.65 (186.13)
30	81.42 (24.82)	127.22 (38.78)	198.78 (60.59)	508.87 (155.10)
35	69.79 (21.27)	109.04 (33.24)	170.38 (51.93)	436.18 (132.95)
40	61.06 (18.61)	95.41 (29.08)	149.08 (45.44)	381.66 (116.33)
45	54.28 (16.54)	84.81 (25.85)	132.52 (40.39)	339.25 (103.40)
50	48.85 (14.89)	76.33 (23.27)	119.27 (36.35)	305.32 (93.06)
55	44.41 (13.54)	69.39 (21.15)	108.42 (33.05)	277.57 (84.60)
60	40.71 (12.41)	63.61 (19.39)	99.39 (30.29)	254.44 (77.55)
65	37.58 (11.45)	58.72 (17.90)	91.74 (27.96)	234.87 (71.59)
70	34.89 (10.64)	54.52 (16.62)	85.19 (25.97)	218.09 (66.47)
75	32.57 (9.93)	50.89 (15.51)	79.51 (24.24)	203.55 (62.04)
80	30.53 (9.31)	47.71 (14.54)	74.54 (22.72)	190.83 (58.16)
85	28.74 (8.76)	44.90 (13.69)	70.16 (21.38)	179.60 (54.74)
90	27.14 (8.27)	42.41 (12.93)	66.26 (20.20)	169.62 (51.70)
95	25.71 (7.84)	40.17 (12.25)	62.77 (19.13)	160.70 (48.98)
100	24.43 (7.45)	38.17 (11.63)	59.63 (18.18)	152.66 (46.53)

# 10 APPENDIX IV THE RELATIONSHIP BETWEEN DC 12V

## CABLE DIAMETER AND THE TRANSMISSION DISTANCE

It is the recommended transmission distance when the cable diameter is fixed and the 12V DC power consumption is below 10%. For the DC device, the max permission voltage power consumption is 10%. The cables used in the following sheet are all copper wires. (the resistivity

of copper is  $\rho = 0.0175\Omega * \text{mm}^2/\text{m}$ )

Feet (m) w	mm			
	0.8000	1.000	1.250	2.000
5	122.13 (37.23)	190.83 (58.16)	298.17 (90.88)	763.31 (232.66)
10	61.06 (18.61)	95.41 (29.08)	149.08 (45.44)	381.66 (116.33)
15	40.71 (12.41)	63.61 (19.39)	99.39 (30.29)	254.44 (77.55)
20	30.53 (9.31)	47.71 (14.54)	74.54 (22.72)	190.83 (58.16)
25	24.43 (7.45)	38.17 (11.63)	59.63 (18.18)	152.66 (46.53)
30	20.35 (6.20)	31.80 (9.69)	49.69 (15.15)	127.22 (38.78)
35	17.45 (5.32)	27.26 (8.31)	42.60 (12.98)	109.04 (33.24)
40	15.27 (4.65)	23.85 (7.27)	37.27 (11.36)	95.41 (29.08)
45	13.57 (4.14)	21.20 (6.46)	33.13 (10.10)	84.81 (28.85)
50	12.21 (3.72)	19.08 (5.82)	29.82 (9.09)	76.33 (23.27)
55	11.10 (3.38)	17.35 (5.29)	27.11 (8.26)	69.39 (21.15)
60	10.18 (3.10)	15.90 (4.85)	24.85 (7.57)	63.61 (19.39)
65	9.39 (2.86)	14.68 (4.47)	22.94 (6.99)	58.72 (17.90)
70	8.72 (2.66)	13.63 (4.15)	21.30 (6.49)	54.52 (16.62)
75	8.14 (2.48)	12.72 (3.88)	19.88 (6.06)	50.89 (15.51)
80	7.63 (2.33)	11.93 (3.64)	18.64 (5.68)	47.71 (14.54)
85	7.18 (2.19)	11.23 (3.42)	17.54 (5.35)	44.90 (13.69)
90	6.78 (2.07)	10.60 (3.23)	16.56 (5.05)	42.41 (12.93)
95	6.43 (1.96)	10.04 (3.06)	15.69 (4.78)	40.17 (12.25)
100	6.11 (1.86)	9.54 (2.91)	14.91 (4.54)	38.17 (11.63)

## 11 APPENDIX V THE RELATIONSHIP BETWEEN DC 24V CABLE

### DIAMETER AND THE TRANSMISSION DISTANCE

It is the recommended transmission distance when the cable diameter is fixed and the DC 24V power consumption is below 10%. For the DC device, the max permission voltage power consumption is 10%. The cables used in the following sheet are all copper wires. (the resistivity of copper is  $\rho = 0.0175\Omega * \text{mm}^2/\text{m}$ )

Feet (m)	mm			
	0.8000	1.000	1.250	2.000
5	148.90	232.66	363.53	930.63
10	74.45	116.33	181.76	465.31
15	49.63	77.55	121.18	310.21
20	37.23	58.16	90.88	232.66
25	29.78	46.53	72.71	186.13
30	24.82	38.78	60.59	155.10
35	21.27	33.24	51.93	132.95
40	18.61	29.08	45.44	116.33
45	16.54	25.85	40.39	103.40
50	14.89	23.27	36.35	93.06
55	13.54	21.15	33.05	84.60
60	12.41	19.39	30.29	77.55
65	11.45	17.90	27.96	71.59
70	10.64	16.62	25.97	66.47
75	9.93	15.51	24.24	62.04
80	9.31	14.54	22.72	58.16
85	8.76	13.69	21.38	54.74
90	8.27	12.93	20.20	51.70
95	7.84	12.25	19.13	48.98
100	7.45	11.63	18.18	46.53



## 12APPENDIX IV THE RELATIONSHIP BETWEEN DC 36V

### CABLE DIAMETER AND THE TRANSMISSION DISTANCE

It is the recommended transmission distance when the cable diameter is fixed and the DC 36V power consumption is below 10%. For the DC device, the max permission voltage power consumption is 10%. The cables used in the following sheet are all copper wires. (The resistivity of copper is  $\rho = 0.0175\Omega * \text{mm}^2/\text{m}$ )

Feet (m)	mm			
	0.8000	1.000	1.250	2.000
W				
5	335.03	523.48	817.94	2093.92
10	167.51	261.74	408.97	1046.96
15	111.68	174.49	272.65	697.97
20	83.76	130.87	204.48	523.48
25	67.01	104.70	163.59	418.78
30	55.84	87.25	136.32	348.99
35	47.86	74.78	116.85	299.13
40	41.88	65.43	102.24	261.74
45	37.23	58.16	90.88	232.66
50	33.50	52.35	81.79	209.39
55	30.46	47.59	74.36	190.36
60	27.92	43.62	68.16	174.49
65	25.77	40.27	62.92	161.07
70	23.93	37.39	58.42	149.57
75	22.34	34.90	54.53	139.59
80	20.94	32.72	51.12	130.87
85	19.71	30.79	48.11	123.17
90	18.61	29.08	45.44	116.33
95	17.63	27.55	43.05	110.21
100	16.75	26.17	40.90	104.70

# 13APPENDIX IV THE RELATIONSHIP BETWEEN DC 48V

## CABLE DIAMETER AND THE TRANSMISSION DISTANCE

It is the recommended transmission distance when the cable diameter is fixed and the DC 48V power consumption is below 10%. For the DC device, the max permission voltage power consumption is 10%. The cables used in the following sheet are all copper wires. (The resistivity of copper is  $\rho = 0.0175\Omega * \text{mm}^2/\text{m}$ )

mm Feet (m) W	0.8000	1.000	1.250	2.000
5	595.60	930.63	1454.11	3722.52
10	297.80	465.31	727.05	1861.26
15	198.53	310.21	484.70	1240.84
20	148.90	232.66	363.53	930.63
25	119.12	186.13	290.82	744.50
30	99.27	155.10	242.35	620.42
35	85.09	132.95	207.73	531.79
40	74.45	116.33	181.76	465.31
45	66.18	103.40	161.57	413.61
50	59.56	93.06	145.41	372.25
55	54.15	84.60	132.19	338.41
60	49.63	77.55	121.18	310.21
65	45.82	71.59	111.85	286.35
70	42.54	66.47	103.86	265.89
75	39.71	62.04	96.94	248.17
80	37.23	58.16	90.88	232.66
85	35.04	54.74	85.54	218.97
90	33.09	51.70	80.78	206.81
95	31.35	48.98	76.53	195.92
100	29.78	46.53	72.71	186.13

## 14 APPENDIX IV WIRE GAUGE REFERENCE SHEET

Metric bare wire diameter (mm)	AWG	SWG	Bare wire cross section (mm <sup>2</sup> )
0.050	43	47	0.00196
0.060	42	46	0.00283
0.070	41	45	0.00385
0.080	40	44	0.00503
0.090	39	43	0.00636
0.100	38	42	0.00785
0.110	37	41	0.00950
0.130	36	39	0.01327
0.140	35		0.01539
0.160	34	37	0.02011
0.180	33		0.02545
0.200	32	35	0.03142
0.230	31		0.04115
0.250	30	33	0.04909
0.290	29	31	0.06605
0.330	28	30	0.08553
0.350	27	29	0.09621
0.400	26	28	0.1257
0.450	25		0.1602
0.560	24	24	0.2463
0.600	23	23	0.2827
0.710	22	22	0.3958
0.750	21		0.4417
0.800	20	21	0.5027
0.900	19	20	0.6362
1.000	18	19	0.7854
1.250	16	18	1.2266
1.500	15		1.7663
2.000	12	14	3.1420
2.500			4.9080
3.000			7.0683

---

**Note**

- This manual is for reference only. Slight difference may be found in the user interface.
- All the designs and software here are subject to change without prior written notice.
- All trademarks and registered trademarks are the properties of their respective owners.
- If there is any uncertainty or controversy, please refer to the final explanation of us.
- Please visit our website or contact your local service engineer for more information.